

TÜRK LOYDU



TL-R P

Requirements Concerning Pipes and Pressure Vessels

July 2019

These requirements are prepared by embedding related IACS Unified Requirements. In order to have consistency, the numbering of the requirements are kept as the same with related IACS Unified Requirements.

Unless otherwise specified, these Rules apply according to the implementation dates as defined in each requirement. See Rule Change Summary on TL website for revision details.

This latest edition incorporates all rule changes.

"General Terms and Conditions" of the respective latest edition will be applicable (see Rules for Classification and Surveys).

If there is a difference between the rules in English and in Turkish, the rule in English is to be considered as valid. This publication is available in print and electronic pdf version. Once downloaded, this document will become UNCONTROLLED. Please check the website below for the valid version.

<http://www.turkloydu.org>

All rights are reserved by Türk Loydu, and content may not be reproduced, disseminated, published, or transferred in any form or by any means, except with the prior written permission of **TL**.

TÜRK LOYDU

Head Office Postane Mah. Tersaneler Cad. No:26 Tuzla 34944 İSTANBUL / TÜRKİYE

Tel : (90-216) 581 37 00

Fax : (90-216) 581 38 00

E-mail : info@turkloydu.org

<http://www.turkloydu.org>

Regional Offices

Ankara Eskişehir Yolu Mustafa Kemal Mah. 2159. Sokak No : 6/4 Çankaya - ANKARA / TÜRKİYE

Tel : (90-312) 219 56 34

Fax : (90-312) 219 68 25

E-mail : ankara@turkloydu.org

İzmir Atatürk Cad. No :378 K.4 D.402 Kavalalılar Apt. 35220 Alsancak - İZMİR / TÜRKİYE

Tel : (90-232) 464 29 88

Fax : (90-232) 464 87 51

E-mail : izmir@turkloydu.org

Adana Çınarlı Mah. Atatürk Cad. Aziz Naci İş Merkezi No:5 K.1 D.2 Seyhan - ADANA / TÜRKİYE

Tel : (90- 322) 363 30 12

Fax : (90- 322) 363 30 19

E-mail : adana@turkloydu.org

CONTENTS

- TL-R P3 Air Pipe Closing Devices
- TL-R P4 Production and Application of Plastic Piping Systems
on Ships
- TL-R P6 Shell type exhaust gas heated economizers that may
be isolated from the steam plant system

TL- R P3 Air Pipe Closing Devices

P3.1 General requirements

Where air pipes are required by the Rules or Load Line Convention, 1966 to be fitted with automatic closing devices, they are to comply with the following:

P3.2 Design

P3.2.1 Air pipe automatic closing devices are to be so designed that they will withstand both ambient and working conditions, and be suitable for use at inclinations up to and including $\pm 40^\circ$.

P3.2.2 Air pipe automatic closing devices are to be constructed to allow inspection of the closure and the inside of the casing as well as changing the seals.

P3.2.3 Efficient ball or float seating arrangements are to be provided for the closures. Bars, cage or other devices are to be provided to prevent the ball or float from contacting the inner chamber in its normal state and made in such a way that the ball or float is not damaged when subjected to water impact due to a tank being overfilled.

P3.2.4 Air pipe automatic closing devices are to be self-draining.

P3.2.5 The clear area through an air pipe closing device in the open position is to be at least equal to the area of the inlet.

P3.2.6 An automatic closing device is to:

- a) Prevent the free entry of water into the tanks,
- b) Allow the passage of air or liquid to prevent excessive pressure or vacuum coming on the tank.

P3.2.7 In the case of air pipe closing devices of the float type, suitable guides are to be provided to ensure unobstructed operation under all working conditions of heel and trim as specified in 3.2.1.

P3.2.8 The maximum allowable tolerances for wall thickness of floats should not exceed $\pm 10\%$ of thickness.

Note:

1. This requirement is applied to any air pipe closing device submitted for new or revised approval from 1 January 2017.

P3.2.9 The inner and the outer chambers of an automatic air pipe head is to be of a minimum thickness of 6 mm. Where side covers are provided and their function is integral to providing functions of the closing device as outlined in P3.2.6, they shall have a minimum wall thickness of 6 mm. If the air pipe head can meet the tightness test in P3.4.1b without the side covers attached, then the side covers are not considered to be integral to the closing device, in which case a wall less than 6 mm can be acceptable for side covers.

P3.3 Materials

P3.3.1 Casings of air pipe closing devices are to be of approved metallic materials adequately protected against corrosion.

P3.3.2 For galvanised steel air pipe heads, the zinc coating is to be applied by the hot method and the thickness is to be 70 to 100 microns.

P3.3.3 For areas of the head susceptible to erosion (e.g. those parts directly subjected to ballast water impact when the tank is being pressed up, for example the inner chamber area above the air pipe, plus an overlap of 10° or more either side) an additional harder coating should be applied. This is to be an aluminium bearing epoxy, or other equivalent, coating, applied over the zinc.

P3.3.4 Closures and seats made of non-metallic materials are to be compatible with the media intended to be carried in the tank and to seawater and suitable for operating at ambient temperatures between -25°C and 85°C.

P3.4 Type Testing

P3.4.1 Testing of Air Pipe Automatic Closing Devices

Each type and size of air pipe automatic closing device is to be surveyed and type tested at the manufacturer's works or other acceptable location according to TL's practice. The minimum test requirements for an air pipe automatic closing device are to include the following:

a) Determination of the Flow Characteristics.

The flow characteristics of the air pipe closing device are to be determined. Measuring of the pressure drop versus rate of volume flow is to be carried out using water and with any intended flame or insect screens in place.

b) Tightness test during immersion/emerging in water.

An automatic closing device is to be subjected to a series of tightness tests involving not less than two (2) immersion cycles under each of the following conditions:

- i) The automatic closing device is to be submerged slightly below the water surface at a velocity of approximately 4 m/min. and then returned to the original position immediately. The quantity of leakage is to be recorded.
- ii) The automatic closing device is to be submerged to a point slightly below the surface of the water. The submerging velocity is to be approximately 8 m/min and the air pipe vent head is to remain submerged for not less than 5 minutes. The quantity of leakage shall be recorded.

- iii) Each of the above tightness tests shall be carried out in the normal position as well as at an inclination of 40 degrees under the strictest conditions for the device. In cases where such strictest conditions are not clear, tests shall be carried out at an inclination of 40 degrees with the device opening facing in three different directions: upward, downward, sideways (left or right). (See Figure 1 to 4).

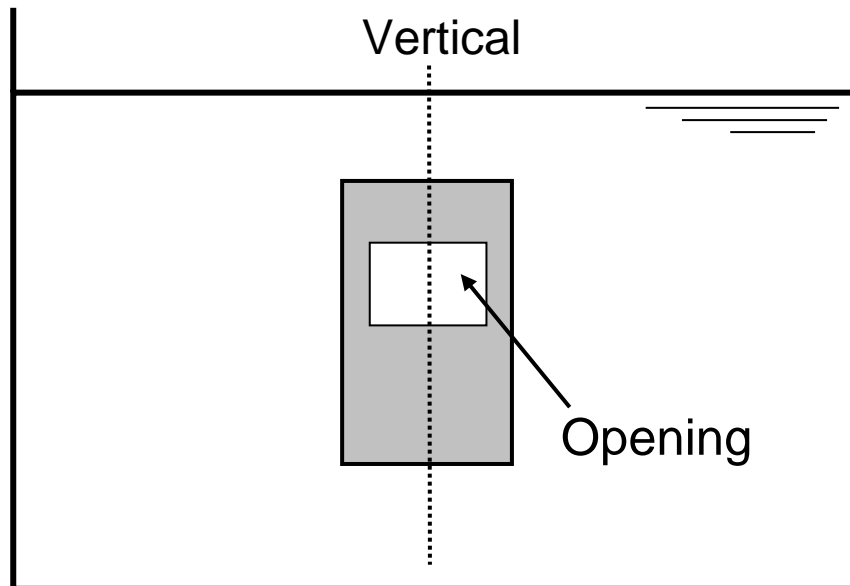

Fig 1: Example of normal position

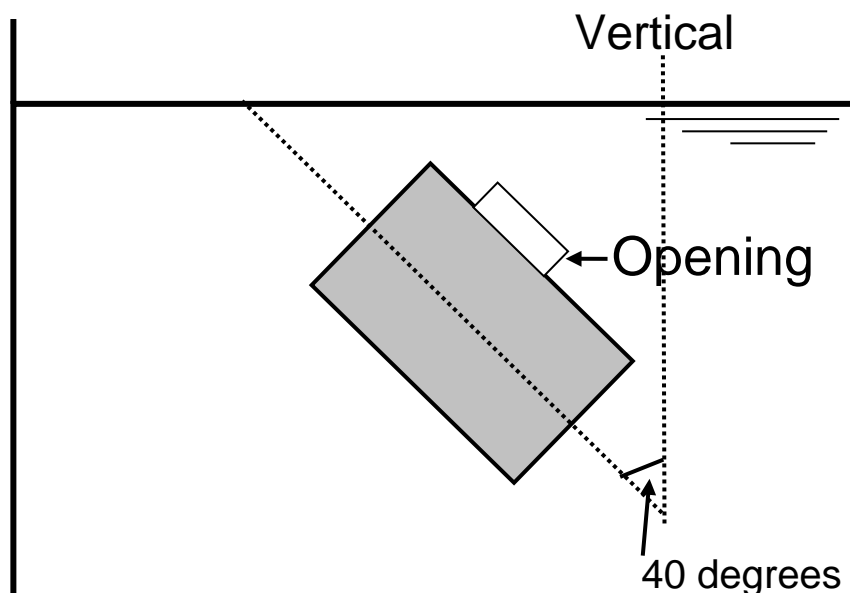

Fig 2: Example of inclination 40 degrees opening facing upward

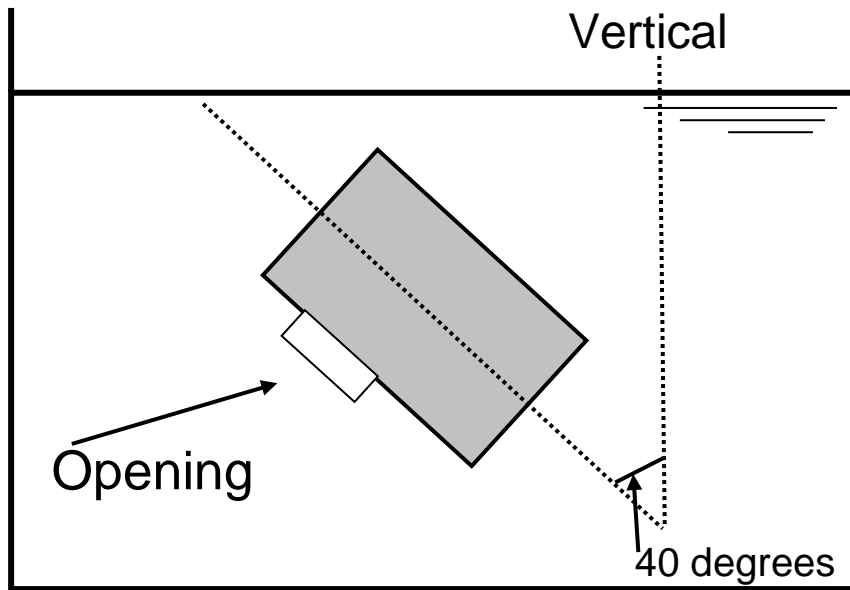

Fig 3: Example of inclination 40 degrees opening facing downward

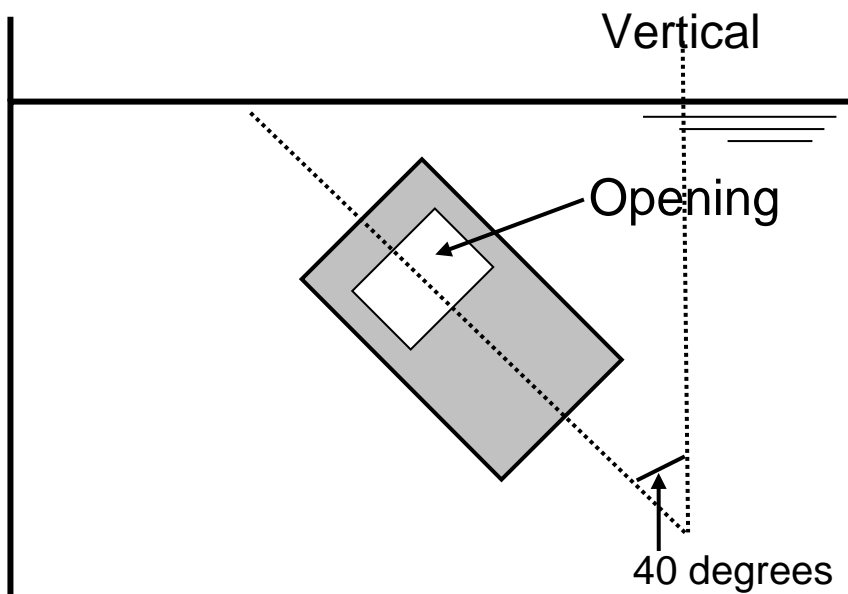

Fig 4: Example of inclination 40 degrees opening facing sideways

c) Discharge / Reverse flow test

The air pipe head shall allow the passage of air to prevent excessive vacuum developing in the tank. A reverse flow test shall be performed. A vacuum pump or another suitable device shall be connected to the opening of the air pipe leading to the tank. The flow velocity shall be applied gradually at a constant rate until the float gets sucked and blocks the flow. The velocity at the point of blocking shall be recorded. 80% of the value recorded will be stated in the certificate.

The maximum allowable leakage per cycle shall not exceed 2 ml/mm of nominal diameter of inlet pipe during any individual test.

P3.4.2 Testing of non-metallic Floats

Impact and compression loading tests shall be carried out on the floats before and after pre-conditioning as follows:

Test condition	Test temperature °C		
	-25	20	85
Dry	+	+	+
After immersing in water	+	+	+
After immersing in fuel oil	-	+	-
Immersing in water and fuel oil is to be for at least 48 hours			

a) Impact Test

The test may be conducted on a pendulum type testing machine. The floats shall be subjected to 5 impacts of 2.5 Nm each and shall not suffer permanent deformation, cracking or surface deterioration at this impact loading. Subsequently the floats shall be subjected to 5 impacts of 25 Nm each. At this impact energy level some localised surface damage at the impact point may occur. No permanent deformation or cracking of the floats shall appear.

b) Compression Loading Test

Compression tests shall be conducted with the floats mounted on a supporting ring of a diameter and bearing area corresponding to those of the float seating with which it is intended that float shall be used. For ball type float, loads shall be applied through a concave cap of the same internal radius as the test float and bearing on an area of the same diameter as the seating. For a disc type float, loads are to be applied through a disc of equal diameter as the float.

A load of 350 kg shall be applied over one minute and maintained for 60 minutes. The deflection shall be measured at intervals of 10 minutes after attachment of the full load. The record of deflection against time is to show no continuing increase in deflection and, after release of the load, there shall be no permanent deflection.

P3.4.3 Testing of Metallic Floats

Tests shall be conducted in accordance with 3.4.2 a). The tests shall be carried out at room temperature and in the dry condition.

TL-R P4 Production and Application of Plastic Pipes on Ships*

P4.1 Terms and Conditions

- .1 "Plastic(s)" means both thermoplastic and thermosetting plastic materials with or without reinforcement, such as PVC and fibre reinforced plastics - FRP.
- .2 "Pipes/piping systems" means those made of plastic(s) and include the pipes, fittings, system joints, method of joining and any internal or external liners, coverings and coatings required to comply with the performance criteria.
- .3 "Joint" means joining pipes by adhesive bonding, laminating, welding, etc.
- .4 "Fittings" means bends, elbows, fabricated branch pieces etc. of plastic materials.
- .5 "Nominal pressure" means the maximum permissible working pressure which should be determined in accordance with the requirements in P 4.3.1.
- .6 "Design pressure" means the maximum working pressure which is expected under operation conditions or the highest set pressure of any safety valve or pressure relief device on the system, if fitted.
- .7 "Fire endurance" means the capability of piping to maintain its strength and integrity (i.e. capable of performing its intended function) for some predetermined period of time while exposed to fire.

P4.2 Scope

- .1 These requirements are applicable to plastic pipes/piping systems on ships.
- .2 The requirements are not applicable to flexible pipes and hoses and mechanical couplings used in metallic piping systems.
- .3 Piping systems made of thermoplastic materials, such as polyethylene(PE), polypropylene(PP), polybutylene(PB) and intended for non-essential services are to meet the requirements of recognized standards and P4.5 and P4.6 of this requirement.

* This requirement addresses the provisions of IMO Res. A.753(18).

Note:

- 1. The requirements of TL-R P4.7 are implemented to any new plastic pipe submitted for approval from 1 January 2007 and to any existing plastic pipe from the date of the first renewal of approval after 1 January 2007.
- 2. The requirements of this TL-R P4.5 are implemented from 1 January 2010.

P4.3 General Requirements

The specification of piping is to be in accordance with a recognised national or international standard acceptable to the Classification Society. In addition, the following requirements apply:

4.3.1 Strength

.1 The strength of the pipes is to be determined by a hydrostatic test failure pressure of a pipe specimen under the standard conditions: atmospheric pressure equal to 100 kPa, relative humidity 30%, environmental and carried fluid temperature 298 kPa (25°C).

.2 The strength of fittings and joints is to be not less than that of the pipes.

.3 The nominal pressure is to be determined from the following conditions:

(i) Internal Pressure

For an internal pressure the following is to be taken whichever is smaller:

$$P_n \text{ int} \leq P_{sth}/4 \text{ or } P_n \text{ int} \leq P_{lth}/2.5$$

where P_{sth} = short-term hydrostatic test failure pressure;

P_{lth} = long-term hydrostatic test failure pressure (> 100,000 h)

(ii) External Pressure

For an external pressure:

$$P_n \text{ ext} \leq P_{col}/3$$

where P_{col} - pipe collapse pressure.

.4 In no case is the collapse pressure to be less than 3 bar.

.5 The maximum working external pressure is a sum of the vacuum inside the pipe and a head of liquid acting on the outside of the pipe.

.6 The maximum permissible working pressure is to be specified with due regard for maximum possible working temperatures in accordance with Manufacturer's recommendations.

4.3.2 Axial Strength

.1 The sum of the longitudinal stresses due to pressure, weight and other loads is not to exceed the allowable stress in the longitudinal direction.

.2 In the case of fibre reinforced plastic pipes, the sum of the longitudinal stresses is not to exceed half of the nominal circumferential stress derived from the nominal internal pressure condition (see P 4.3.1).

4.3.3 Impact Resistance

.1 Plastic pipes and joints are to have a minimum resistance to impact in accordance with recognized national or international standards.

.2 After the test the specimen is to be subjected to hydrostatic pressure equal to 2.5 times the design pressure for at least 1 hour.

4.3.4 Temperature

.1 The permissible working temperature depending on the working pressure is to be in accordance with Manufacturer's recommendations, but in each case it is to be at least 20°C lower than the minimum heat distortion temperature of the pipe material, determined according to ISO 75 method A, or equivalent.

.2 The minimum heat distortion temperature is to be not less than 80°C.

P4.4 Requirements for Pipes/Piping Systems Depending on Service and/or Locations

4.4.1 Fire endurance

.1 Pipes and their associated fittings whose integrity is essential to the safety of ships are required to meet the minimum fire endurance requirements of Appendix 1 or 2, as applicable, of IMO Res A.753(18).

.2 Depending on the capability of a piping system to maintain its strength and integrity, there exist three different levels of fire endurance for piping systems.

- (i) Level 1. Piping having passed the fire endurance test specified in Appendix 1 of IMO Res. A.753(18) for a duration of a minimum of one hour without loss of integrity in the dry condition is considered to meet level 1 fire endurance standard (L1).
- (ii) Level 2. Piping having passed the fire endurance test specified in Appendix 1 of IMO Res. A.753(18) for a duration of a minimum of 30 minutes in the dry condition is considered to meet level 2 fire endurance standard (L2).
- (iii) Level 3. Piping having passed the fire endurance test specified in Appendix 2 of IMO Res. A.753 (18) for a duration of a minimum of 30 minutes in the wet condition is considered to meet level 3 fire endurance standard (L3).

.3 Permitted use of piping depending on fire endurance, location and piping system is given in Table 1 "Fire Endurance Requirement Matrix".

Table 1 Fire Endurance Requirements Matrix

N	Piping Systems	Location										
		A	B	C	D	E	F	G	H	I	J	K
		Machinery spaces of category A	Other machinery spaces & pump rooms	Cargo pump rooms	Ro/Ro cargo holds	Other dry cargo holds	Cargo tanks	Fuel oil tanks	Ballast water tanks	Cofferdams void spaces pipe tunnel & ducts	Accommodation service & control spaces	Open decks
1	2	3	4	5	6	7	8	9	10	11	12	13

CARGO (FLAMMABLE CARGOES f.p.≤60°C)

1.	Cargo lines	NA	NA	L1	NA	NA	O	NA	O ¹⁰	O	NA	L1 ²
2.	Crude Oil washing lines	NA	NA	L1	NA	NA	O	NA	O ¹⁰	O	NA	L1 ²
3.	Vent lines	NA	NA	NA	NA	NA	O	NA	O ¹⁰	O	NA	X

INERT GAS

4.	Water seal effluent line	NA	NA	O ¹	NA	NA	O ¹	O ¹	O ¹	O ¹	NA	O
5.	Scrubber effluent line	O ¹	O ¹	NA	NA	NA	NA	NA	O ¹	O ¹	NA	O
6.	Main Line	O	O	L1	NA	NA	NA	NA	NA	O	NA	L1 ⁶
7.	Distribution lines	NA	NA	L1	NA	NA	O	NA	NA	O	NA	L1 ²

FLAMMABLE LIQUIDS (f.p. > 60°C)

8.	Cargo lines	X	X	L1	X	X	NA ³	O	O ¹⁰	O	NA	L1
9.	Fuel oil	X	X	L1	X	X	NA ³	O	O	O	L1	L1
10.	Lubricating	X	X	L1	X	X	NA	NA	NA	O	L1	L1
11.	Hydraulic oil	X	X	L1	X	X	O	O	O	O	L1	L1

SEAWATER¹

12.	Bilge main & branches	L1 ⁷	L1 ⁷	L1	X	X	NA	O	O	O	NA	L1
13.	Fire main & water spray	L1	L1	L1	X	NA	NA	NA	O	O	X	L1
14.	Foam system	L1	L1	L1	NA	NA	NA	NA	NA	O	L1	L1
15.	Sprinkler system	L1	L1	L3	X	NA	NA	NA	O	O	L3	L3
16.	Ballast	L3	L3	L3	L3	X	O ¹⁰	O	O	O	L2	L2
17.	Cooling water, essential services	L3	L3	NA	NA	NA	NA	NA	O	O	NA	L2
18.	Tank cleaning services fixed machines	NA	NA	L3	NA	NA	O	NA	O	O	NA	L3 ²
19.	Non-essential systems	O	O	O	O	O	NA	O	O	O	O	O

FRESHWATER

20.	Cooling water essential services	L3	L3	NA	NA	NA	NA	O	O	O	L3	L3
21.	Condensate return	L3	L3	L3	O	O	NA	NA	NA	O	O	O
22.	Non-essential systems	O	O	O	O	O	NA	O	O	O	O	O

SANITARY/ DRAINS/ SCUPPERS

23.	Deck drains (internal)	L1 ⁴	L1 ⁴	NA	L1 ⁴	O	NA	O	O	O	O	O
24.	Sanitary drains (internal)	O	O	NA	O	O	NA	O	O	O	O	O
25.	Scuppers and discharges (overboard)	O ^{1.8}	O ^{1.8}	O ^{1.8}	O ^{1.8}	O ^{1.8}	O	O	O	O	O ^{1.8}	O

SOUNDING/AIR

26.	Water tanks/ dry spaces	O	O	O	O	O	O ¹⁰	O	O	O	O	O
27.	Oil Tanks (fp. > 60°C)	X	X	X	X	X	X ³	O	O ¹⁰	O	X	X

MISCELLANEOUS

28.	Control air	L1 ⁵	L1 ⁵	L1 ⁵	L1 ⁵	L1 ⁵	NA	O	O	O	L1 ⁵	L1 ⁵
29.	Service air (non essential)	O	O	O	O	O	NA	O	O	O	O	O
30.	Brine	O	O	NA	O	O	NA	NA	NA	O	O	O
31.	Auxillary low pressure steam (≤ 7 bar)	L2	L2	O ⁹	O ⁹	O ⁹	O	O	O	O	O ⁹	O ⁹

ABBREVIATIONS:

- L1 Fire endurance test (appendix 1) in dry conditions, 60 min
- L2 Fire endurance test (appendix 1) in dry conditions, 30 min
- L3 Fire endurance test (appendix 2) in wet conditions, 30 min
- O No fire endurance test required
- NA Not applicable
- X Metallic materials having a melting point greater than 925°C

FOOTNOTES:

1. Where non-metallic piping is used, remotely controlled valves to be provided at ship's side (valve is to be controlled from outside space).
2. Remote closing valves to be provided at the cargo tanks.
3. When cargo tanks contain flammable tanks with f.p. > 60°C, "O" may replace "NA" or "X".
4. For drains serving only the space concerned, "O" may replace "L1".

5. When controlling functions are not required by statutory requirements or guidelines, "O" may replace "L1".
6. For pipe between machinery space and deck water seal, "O" may replace "L1".
7. For passenger vessels, "X" is to replace "L1".
8. Scuppers serving open decks in positions 1 and 2, as defined in regulation 13 of the International Convention on Load Lines, 1966, should be "X" throughout unless fitted at the upper end with the means of closing capable of being operated from a position above the freeboard deck in order to prevent downflooding.
9. For essential services, such as fuel oil tank heating and ships whistle, "X" is to replace "O".
10. For tankers where compliance with paragraph 3 (f) of regulation 13F of Annex I of MARPOL 73/78 is required, "NA" is to replace "O".

LOCATION DEFINITIONS:

Location	Definition
A - Machinery spaces of category A	Machinery spaces of category A as defined in SOLAS* regulation II-2/3.19.
B - Other machinery spaces and pump rooms	Spaces, other than category A machinery spaces and cargo pump rooms, containing propulsion machinery, boilers, steam and internal combustion engines, generators and major electrical machinery, pumps, oil filling stations, refrigerating, stabilising, ventilation and air-conditioning machinery, and similar spaces and trunks to such spaces.
C - Cargo pump rooms	Spaces containing cargo pumps and entrances and trunks to such spaces.
D - Ro-ro cargo holds	Ro-ro cargo holds are ro-ro cargo spaces and special category spaces and special category spaces as defined in SOLAS* regulation II-2/3.14 and 3.18.
E - Other dry cargo holds	All spaces other than ro-ro cargo holds used for non- liquid cargo and trunks to such spaces.
F - Cargo tanks	All spaces used for liquid cargo and trunks to such spaces.
G - Fuel oil tanks	All spaces used for fuel oil (excluding cargo tanks) and trunks to such spaces.
H - Ballast water tanks	All spaces used for ballast water and trunks to such spaces.
I - Cofferdams, voids, etc.	Cofferdams and voids are those empty spaces between two bulkheads separating two adjacent compartments.

J - Accommodation, service	Accommodation spaces, service spaces and control stations as defined in SOLAS* regulation II-2/3.10, 3.12, 3.22.
K - Open decks	Open deck spaces as defined in SOLAS* regulation II-2/26.2.2. (5).

* SOLAS 74 as amended by the 1978 SOLAS Protocol and the 1981 and 1983 amendments (consolidated text).

4.4.2 Flame Spread

.1 All pipes, except those fitted on open decks and within tanks, cofferdams, pipe tunnels, and ducts are to have low surface flame spread characteristics not exceeding average values listed in IMO Resolution A.653(16).

.2 Surface flame spread characteristics are to be determined using the procedure given in IMO Resolution A.653(16) with regard to the modifications due to the curvilinear pipe surfaces as listed in Appendix 3 of IMO Resolution A.753(18).

.3 Surface flame spread characteristics may also be determined using the text procedures given in ASTM D635, or in other national equivalent standards.

4.4.3 Fire Protection Coatings

.1 Where a fire protective coating of pipes and fittings is necessary for achieving the fire endurance level required, it is to meet the following requirements:

- (i) The pipes are generally to be delivered from the manufacturer with the protective coating on.
- (ii) The fire protection properties of the coating are not to be diminished when exposed to salt water, oil or bilge slops. It is to be demonstrated that the coating is resistant to products likely to come into contact with the piping.
- (iii) In considering fire protection coatings, such characteristics as thermal expansion, resistance against vibrations, and elasticity are to be taken into account.
- (iv) The fire protection coatings are to have sufficient resistance to impact to retain their integrity.

4.4.4 Electrical Conductivity

Where electrical conductivity is to be ensured, the resistance of the pipes and fittings is not to exceed 1×10^5 Ohm/m.

P4.5 Material approval and Quality Control During Manufacture

.1 Prototypes of pipes and fittings are to be tested to determine short-term and long-term design strength, fire endurance and low surface flame spread characteristics (if applicable), electrical resistance (for electrically conductive pipes), impact resistance in accordance with this requirement.

.2 For prototype testing representative samples of pipes and fittings are to be selected to the satisfaction of the Classification Society.

.3 The Manufacturer is to have quality system that meets ISO 9000 series standards or equivalent. The quality system is to consist of elements necessary to ensure that pipes and fittings are produced with consistent and uniform mechanical and physical properties.

.4 Each pipe and fitting is to be tested by the Manufacturer at a hydrostatic pressure not less than 1.5 times the nominal pressure. Alternatively, for pipes and fittings not employing hand lay up techniques, the hydrostatic pressure test may be carried out in accordance with the hydrostatic testing requirements stipulated in the recognised national or international standard to which the pipe or fittings are manufactured, provided that there is an effective quality system in place.

.5 Piping and fittings are to be permanently marked with identification. Identification is to include pressure ratings, the design standards that the pipe or fitting is manufactured in accordance with, and the material of which the pipe or fitting is made.

.6 In case the Manufacturer does not have an approved quality system complying with ISO 9000 series or equivalent, pipes and fittings are to be tested in accordance with this requirement to the satisfaction of the Classification Society's surveyors for every batch of pipes.

.7 Depending upon the intended application a Society may require the pressure testing of each pipe and/or fitting.

P4.6 Installation

4.6.1 Supports

.1 Selection and spacing of pipe supports in shipboard systems are to be determined as a function of allowable stresses and maximum deflection criteria. Support spacing is not to be greater than the pipe Manufacturer's recommended spacing. The selection and spacing of pipe supports are to take into account pipe dimensions, mechanical and physical properties of the pipe material, mass of pipe and contained fluid, external pressure, operating temperature, thermal expansion effects, loads due to external forces, thrust forces, water hammer, vibrations, maximum accelerations to which the system may be subjected. Combination of loads is to be considered.

.2 Each support is to evenly distribute the load of the pipe and its contents over the full width of the support. Measures are to be taken to minimize wear of the pipes where they contact the supports.

.3 Heavy components in the piping system such as valves and expansion joints are to be independently supported.

4.6.2 Expansion

.1 Suitable provision is to be made in each pipeline to allow for relative movement between pipes made of plastic and the steel structure, having due regard to:

- (i) the difference in the coefficients of thermal expansion;
- (ii) deformations of the ship's hull and its structure.

2. When calculating the thermal expansions, account is to be taken of the system working temperature and the temperature at which assembly is performed.

4.6.3 External Loads

.1 When installing the piping, allowance is to be made for temporary point loads, where applicable. Such allowances are to include at least the force exerted by a load (person) of 100 kg at mid-span on any pipe of more than 100 mm nominal outside diameter.

.2 Besides for providing adequate robustness for all piping including open-ended piping a minimum wall thickness, complying with 4.3.1, may be increased upon the demand of the Classification society taking into account the conditions encountered during service on board ships.

.3 Pipes are to be protected from mechanical damage where necessary.

4.6.4 Strength of Connections

.1 The strength of connections is to be not less than that of the piping system in which they are installed.

.2 Pipes may be assembled using adhesive-bonded, welded, flanged or other joints.

.3 Adhesives, when used for joint assembly, are to be suitable for providing a permanent seal between the pipes and fittings throughout the temperature and pressure range of the intended application.

.4 Tightening of joints is to be performed in accordance with Manufacturer's instructions.

4.6.5 Installation of Conductive Pipes

.1 In piping systems for fluids with conductivity less than 1000 pico siemens per metre (pS/m) such as refined products and distillates use is to be made of conductive pipes.

.2 Regardless of the fluid being conveyed, plastic piping is to be electrically conductive if the piping passes through a hazardous area. The resistance to earth from any point in the piping system is not to exceed 1×10^6 Ohm. It is preferred that pipes and fittings be homogeneously conductive. Pipes and fittings having conductive layers are to be protected against a possibility of spark damage to the pipe wall. Satisfactory earthing is to be provided.

.3 After completion of the installation, the resistance to earth is to be verified. Earthing wires are to be accessible for inspection.

4.6.6 Application of Fire Protection Coatings

.1 Fire protection coatings are to be applied on the joints, where necessary for meeting the required fire endurance as for 4.4.3, after performing hydrostatic pressure tests of the piping system.

.2 The fire protection coatings are to be applied in accordance with Manufacturer's recommendations, using a procedure approved in each particular case.

4.6.7 Penetration of Divisions

.1 Where plastic pipes pass through "A" or "B" class divisions, arrangements are to be made to ensure that the fire endurance is not impaired. These arrangements are to be tested in accordance with Recommendations for fire test procedures for "A", "B" and "F" bulkheads (Resolution A.754(18) as amended).

.2 When plastic pipes pass through watertight bulkheads or decks, the watertight integrity of the bulkhead or deck is to be maintained.

.3 If the bulkhead or deck is also a fire division and destruction by fire of plastic pipes may cause the inflow of liquid from tanks, a metallic shut-off valve operable from above the freeboard deck should be fitted at the bulkhead or deck.

4.6.8 Control During Installation

.1 Installation is to be in accordance with the Manufacturer's guidelines.

2. Prior to commencing the work, joining techniques are to be approved by the Classification Society.

3. The tests and explanations specified in this requirement are to be completed before shipboard piping installation commences.

4. The personnel performing this work are to be properly qualified and certified to the satisfaction of the Classification Society.

5. The procedure of making bonds is to include:

- (i) materials used,
- (ii) tools and fixtures,
- (iii) joint preparation requirements,
- (iv) cure temperature,
- (v) dimensional requirements and tolerances, and
- (vi) tests acceptance criteria upon completion of the assembly.

.6 Any change in the bonding procedure which will affect the physical and mechanical properties of the joint is to require the procedure to be requalified.

4.6.9 Bonding Procedure Quality Testing

.1 A test assembly is to be fabricated in accordance with the procedure to be qualified and it is to consist of at least one pipe-to-pipe joint and one pipe-to-fitting joint.

.2 When the test assembly has been cured, it is to be subjected to a hydrostatic test pressure at a safety factor 2.5 times the design pressure of the test assembly, for not less than one hour. No leakage or separation of joints is allowed. The test is to be conducted so that the joint is loaded in both longitudinal and circumferential directions.

.3 Selection of the pipes used for test assembly, is to be in accordance with the following:

- (i) When the largest size to be joined is 200 mm nominal outside diameter, or smaller, the test assembly is to be the largest piping size to be joined.
- (ii) When the largest size to be joined is greater than 200 mm nominal outside diameter, the size of the test assembly is to be either 200 mm or 25% of the largest piping size to be joined, whichever is greater.

.4 When conducting performance qualifications, each bonder and each bonding operator are to make up test assemblies, the size and number of which are to be as required above.

4.6.10 Testing After Installation on Board

- .1 Piping systems for essential services are to be subjected to a test pressure not less than 1.5 times the design pressure or 4 bar whichever is greater.
- .2 Piping systems for non-essential services are to be checked for leakage under operational conditions.
- .3 For piping required to be electrically conductive, earthing is to be checked, and random resistance testing is to be conducted.

P4.7 Test Specification For Plastic Pipes

4.7.1 Scope

Section P4.7 contains requirements for the Type Approval of plastic pipes. It is applicable to rigid pipes, pipe joints and fittings.

4.7.2 Documentation

The following information for the plastic pipes, fittings and joints is to be submitted for consideration and approval:

- I. General Information
 1. Pipe and fitting dimensions
 2. Maximum internal and external working pressure
 3. Working temperature range
 4. Intended services and installation locations
 5. The level of fire endurance
 6. Electrically conductive
 7. Intended fluids
 8. Limits on flow rates
 9. Serviceable life
 10. Installation instructions
 11. Details of marking
- II. Drawings and supporting documentation:
 1. Certificates and reports for relevant tests previously carried out.
 2. Details of relevant standards.
 3. All relevant design drawings, catalogues, data sheets, calculations and functional descriptions.
 4. Fully detailed sectional assembly drawings showing pipe, fittings and pipe connections.
- III. Materials
 1. The resin type.
 2. Catalyst and accelerator types, and concentration employed in the case of reinforced polyester resin pipes or hardeners where epoxide resins are employed.
 3. A statement of all reinforcements employed where the reference number does not identify the mass per unit area or the tex number of a roving used in a filament winding process, these are to be detailed.

-
4. Full information regarding the type of gel-coat or thermoplastic liner employed during construction, as appropriate.
 5. Cure/post-cure conditions. The cure and post cure temperatures and times employ resin/reinforcement ratio.
 6. Winding angle and orientation.

4.7.3 Testing

Testing is to demonstrate compliance of the pipes, fittings and joints for which Type Approval is sought with TL-R P4.

Pipes, joints and fittings are to be tested for compliance with the requirements of standards* acceptable to classification society.

* For the lists of standards refer to TL-G 86.

TL- R P6 Shell Type Exhaust Gas Heated Economizers That May Be Isolated From The Steam Plant System

P6.1 Application

This requirement is applicable to shell type exhaust gas heated economizers that are intended to be operated in a flooded condition and that may be isolated from the steam plant system.

All shell type exhaust gas heated economizers that may be isolated from the steam plant system in a flooded condition and which are fitted on board ships contracted for construction on or after 1 January 2007 are to comply with this requirement.

P6.2 Design and Construction

Design and construction of shell type economizers are to pay particular attention to the welding, heat treatment and inspection arrangements at the tube plate connection to the shell.

P6.3 Pressure Relief

P6.3.1 Where a shell type economizer is capable of being isolated from the steam plant system, it is to be provided with at least one safety valve, and when it has a total heating surface of 50 m² or more, it is to be provided with at least two safety valves in accordance with TL requirements.

P6.3.2 To avoid the accumulation of condensate on the outlet side of safety valves, the discharge pipes and/or safety valve housings are to be fitted with drainage arrangements from the lowest part, directed with continuous fall to a position clear of the economizer where it will not pose threats to either personnel or machinery. No valves or cocks are to be fitted in the drainage arrangements.

Note:

1. This requirement is implemented for shell type exhaust gas heated economizers:
 - i) when an application for certification of a shell type exhaust gas heated economizers is dated on or after 1 July 2016; or
 - ii) which are installed in new ships for which the date of contract for construction is on or after 1 July 2016.
2. The “contracted for construction” date means the date on which the contract to build the vessel is signed between the prospective owner and the shipbuilder. For further details regarding the date of “contract for construction”, refer to TL- PR 29.

P6.3.3 Full details of the proposed arrangements to satisfy P6.3.1 to P6.3.2 are to be submitted for approval.

P6.4 Pressure Indication

Every shell type economizer is to be provided with a means of indicating the internal pressure. A means of indicating the internal pressure is to be located so that the pressure can be easily read from any position from which the pressure may be controlled.

P6.5 Lagging

Every shell type economizer is to be provided with removable lagging at the circumference of the tube end plates to enable ultrasonic examination of the tube plate to shell connection.

P6.6 Feed Water

Every economizer is to be provided with arrangements for pre-heating and de-aeration, addition of water treatment or combination thereof to control the quality of feed water to within the manufacturer's recommendations.

P6.7 Operating Instructions

The manufacturer is to provide operating instructions for each economizer which is to include reference to:

- Feed water treatment and sampling arrangements.
- Operating temperatures – exhaust gas and feed water temperatures.
- Operating pressure.
- Inspection and cleaning procedures.
- Records of maintenance and inspection.
- The need to maintain adequate water flow through the economizer under all operating conditions.
- Periodical operational checks of the safety devices to be carried out by the operating personnel and to be documented accordingly.
- Procedures for using the exhaust gas economizer in the dry condition.
- Procedures for maintenance and overhaul of safety valves.